



Scaleable Solutions

WIRELESS

RELIABLE

ECONOMICAL

ACCURATE

# PCS Digital Crane Scale

Designed for demanding industrial use

Approved for commercial weighing

User-friendly operation in every environment

Vaa'at

Scales

Vekter

Balanças

电子秤

Vågar

ВЕСЫ

Waagen

कांटा

Básculas

Svari

Svarstýklés

الموازين

Vægte

Kaalud

Vogir

Balances

wagi

váhy



## Benefits

- Superior accuracy - reliability
- Legal for trade - direct invoicing
- High durability - maintenance free
- Advanced design - easy & convenient operation
- Weighing on site - save time and money
- Plug & Play - no lead time in start-up
- Robust construction - improved safety
- USB and Radio Data Transfer - flexible & quick



**TAMTRON**<sup>®</sup>  
Scaleable Solutions

[www.tamtron.fi](http://www.tamtron.fi)

# Robust and compact design Portable Crane Scale PCS

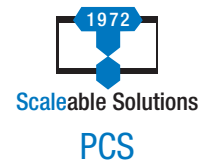

## Revolutional wireless handheld unit DR10

Tamtron DR10 represents a new generation of radio remote controllers for Tamtron crane scales. This advanced handheld unit has a bright graphical display, simple menu based user interface and easy-to-use keyboard. With the DR10 the user can send commands to the scale and view the weight from a distance without seeing the scale display.



The DR10 handheld has a summing function and non-volatile data memory for up to 1000 weighing results with time and date label. The data can be transferred to PC conveniently via USB connection. Furthermore, the USB is used also to charge the unit's battery.

## Dimensions

Capacity (kg)	Dimensions (mm)								
	A	B	C	D	E	F	G	H	I
500	200	181	110	427	28	60	16	110	170
2000	200	181	110	427	28	60	16	110	170
3200	200	181	110	477,5	33	75	18	135	170
6300	200	181	110	545	40	90	23	160	170
8000	200	181	110	599	49	100	27	180	170
10000	200	181	110	599	49	100	27	180	170

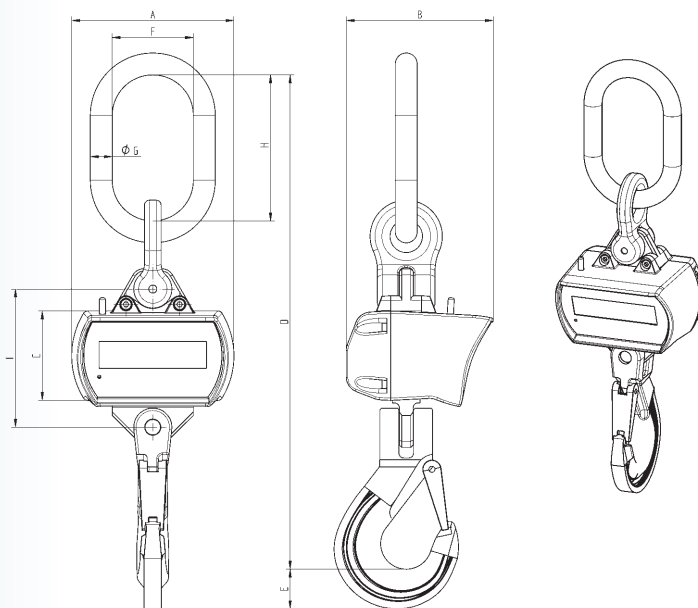

### Technical data: DR10

- Display:** 64x128 graphical LCD with white LED backlight
- Operational range:** Up to 200 m on the line of sight
- Non-volatile memory:** 1000 weighing records with time and date
- USB connection:** Data upload to PC via USB cable
- Battery type:** 2 x NiMH AA Cells, 2100mAh
- Radio frequency:** 433.23Mhz - 434.35Mhz /10 user selectable channels
- Operation time:** Full backlight on: 24 hours  
Backlight off: 47 hours
- Charge time:** 5 hours from PC USB-port
- Weight:** 200 gr total
- Operation temperature:** -10°C to +55°C

## The Delivery includes

- DR10
- Safety Hook
- Lifting ring

## Options

- Short radio data transfer to PC
- LED display
- Standard infrared remote controller
- Log memory

## Sales by weight - fair business

The invoicing is based on the real amount loaded. The laws concerning commercial weighing require that the scale has to be approved for commercial use when sales is done based on weight. This kind of legal for trade scale can be recognised and the validity time seen from the stickers placed by local notified body. Moreover, a legal for trade scale is ideal also for control weighing due to its reliability.



## Tamtron Group - reliable weighing equipment suppliers

Reliability is a result of know-how, quality work, continuity and resources. For Tamtron has been granted an ISO 9001:2000 quality certificate and rights to do initial verifications and service approvals. Tamtron Group and its wide network of qualified distributors all over the world take care of sales, approval and service quickly and economically.

**TAMTRON OY**  
P.O. Box 15, (Vestonkatu 11)  
FI-33561 Tampere, Finland  
Tel. +358 3 3143 5000  
Fax +358 3 3143 5050  
Email: weighing@tamtron.fi  
www.tamtron.fi

### Technical data: Scale unit

- Accuracy  $\pm 0,05$  % of capacity
- Four digit 25 mm LCD display with backlight
- Taring 100 % of capacity
- Gross/net function
- Load cell breaking strength 500 % of capacity
- Allowed peak load 200 % of capacity
- Overload warning
- Operation time with fully charged battery at least 200 hours
- Operation temperature range: -20°C...+50°C
- IP 65 cast aluminium case



Tamtron Group consists of Tamtron Oy, Tamtron Systems Oy, Tamtron Servers Oy and Tamtron Solutions Oy. Furthermore, Tamtron has subsidiaries in Sweden, Poland, Czech Republic, France and Estonia. Tamtron Group is specialised in deliveries of weighing equipment and information systems for demanding conditions. The Group has export to over 50 countries and over 20 000 deliveries worldwide.

